

**CA16 and CA16S-14**  
**Air and Gas trap**  
**Installation and Maintenance Instructions**

**CA16 and CA16S-14**  
 $\frac{1}{2}$ " and  $\frac{3}{4}$ "

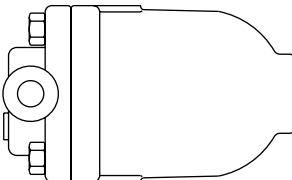
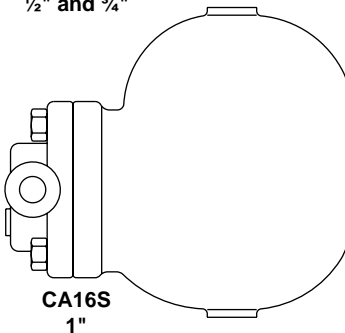

**CA16S**  
1"

1. *General safety information*
2. *General product information*
3. *Installation*
4. *Commissioning*
5. *Operation*
6. *Maintenance*
7. *Spare parts*

# 1. General safety information

Safe operation of these units can only be guaranteed if they are properly installed, commissioned and maintained by a qualified person (see Section 11 of the attached Supplementary Safety Information) in compliance with the operating instructions. General installation and safety instructions for pipeline and plant construction, as well as the proper use of tools and safety equipment must also be complied with.

## Warning

The cover gasket contains a thin stainless steel support ring which may cause physical injury if not handled and disposed of carefully.

## Isolation

Consider whether closing isolating valves will put any other part of the system or personnel at risk. Dangers might include; isolation of vents and protective devices or alarms. Ensure isolation valves are turned off in a gradual way to avoid system shocks.

## Pressure

Before attempting any maintenance consider what is or may have been in the pipeline. Ensure that any pressure is isolated and safely vented to atmospheric pressure before attempting to maintain the product, this is easily achieved by fitting Spirax Sarco depressurisation valves type DV (see separate literature for details). Do not assume that the system is depressurised even when a pressure gauge indicates zero.

## Temperature

Allow time for temperature to normalise after isolation to avoid the danger of burns and consider whether protective clothing (including safety glasses) is required. If parts made from Viton have been subjected to a temperature approaching 315°C (599°F) or higher, they may have decomposed and formed hydrofluoric acid. Avoid skin contact and inhalation of any fumes as the acid will cause deep skin burns and damage the respiratory system.

## Disposal

These products are recyclable. No ecological hazard is anticipated with the disposal of these products providing due care is taken, EXCEPT;

### Viton:

- Can be landfilled, when in compliance with National and Local regulations.
- Can be incinerated, but a scrubber must be used to remove Hydrogen Fluoride, which is evolved from the product and with the compliance to National and Local regulations.
- Is insoluble in aquatic media.

## — 2. General product information —

### 2.1 General description

The CA16 is a maintainable austenitic stainless steel ball float air and gas trap. It is supplied with a soft Viton valve cone given designation CA16 (DN15 and DN20 only) or with a metal valve cone given designation CA16S-14 both having horizontal screwed connections. The cover will be drilled and tapped  $\frac{3}{8}$ " BSP or NPT for the purpose of fitting a balance line.

**Note:** For additional information see the Technical Information Sheet TI-P148-05.

### 2.2 Sizes and pipe connection

$\frac{1}{2}$ ",  $\frac{3}{4}$ " and 1" screwed BSP or NPT.

Fig. 1

CA16 and CA16S-14

$\frac{1}{2}$ " and  $\frac{3}{4}$ "

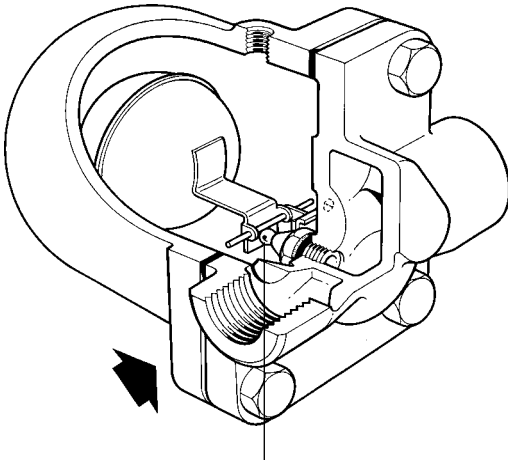

Viton valve cone  
CA16 only

Fig. 2  
CA16S-14  
1"

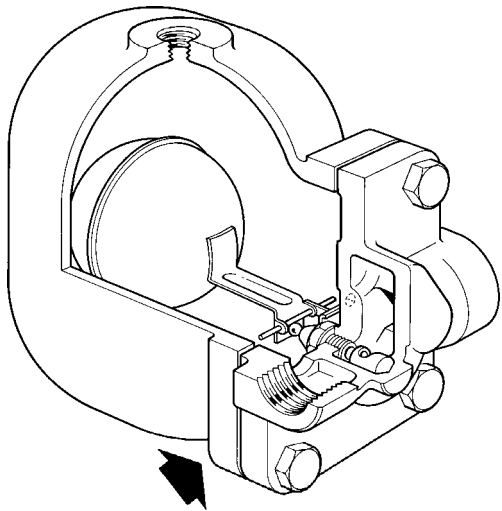

## 2.3 Limiting conditions

Body design conditions	PN25	
PMA - Maximum allowable pressure	25 bar g	(362.5 psi g)
TMA - Maximum allowable temperature	300°C	(572°F)
TMO - Maximum operating temperature	CA16	200°C (392°F)
	CA16S-14	300°C (572°F)
PMO - Maximum operating pressure	25 bar g	(362.5 psi g)
Δ PMX Maximum differential pressure	14 bar	(203 psi)
Designed for a maximum cold hydraulic test pressure of:	37.5 bar g	(544 psi g)

## 2.4 Operating range

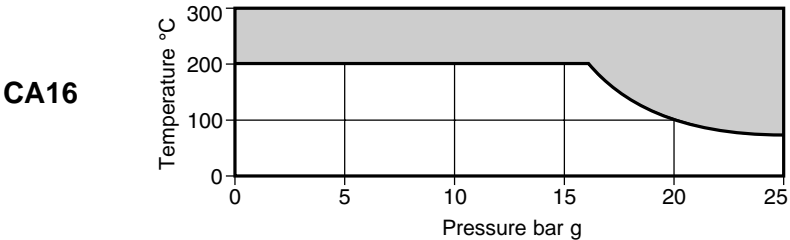
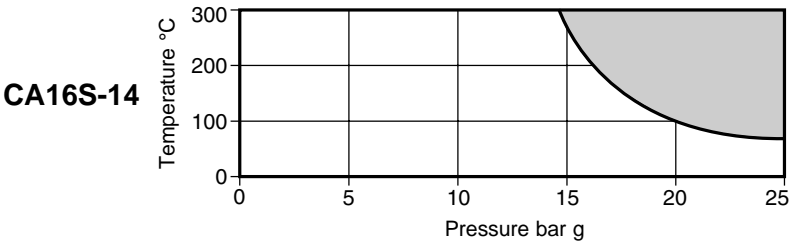

 The product should not be used in this region.

### Δ PMX - Maximum differential pressure

Depending on the specific gravity of the liquid being drained

Specific gravity	1.0	0.9	0.8	0.7	0.6
<b>CA16</b>	14 bar	14 bar	11 bar	8 bar	5 bar
<b>CA16S-14</b>	14 bar	14 bar	11 bar	8 bar	5 bar

# 3. Installation

**Note:** Before actioning any installation observe the 'Safety information' in Section 1.

Referring to the Installation and Maintenance Instructions, name-plate and Technical Information Sheet, check that the product is suitable for the intended installation:

- 3.1** Check materials, pressure and temperature and their maximum values. If the maximum operating limit of the product is lower than that of the system in which it is being fitted, ensure that a safety device is included in the system to prevent overpressurisation.
- 3.2** Determine the correct installation situation and the direction of fluid flow.
- 3.3** Remove protective covers from all connections.
- 3.4** The trap must be fitted with the float arm in a horizontal plane so that the float mechanism is free to rise and fall in a vertical plane.  
The trap must be fitted below what it is draining. Point arrow on name-plate downwards. One of the advantages of the float trap for draining air and gas systems is that no bleed is required for satisfactory operation. However, because the trap has no bleed a separate balance line is needed to prevent it becoming air or gas locked. It should be noted that the balance line is piped back to the upstream side.  
**Important note: A balance line is essential for the correct operation of this product.** For convenience of maintenance it is recommended that a union is fitted in the balance line near to the trap cover.

**Note:** If the trap is to discharge to atmosphere ensure it is to a safe place, the discharging fluid may be at a temperature of 100°C (212°F).

### Example showing installation and balance line arrangement

For more examples of installation and balance line arrangements, see page 6.

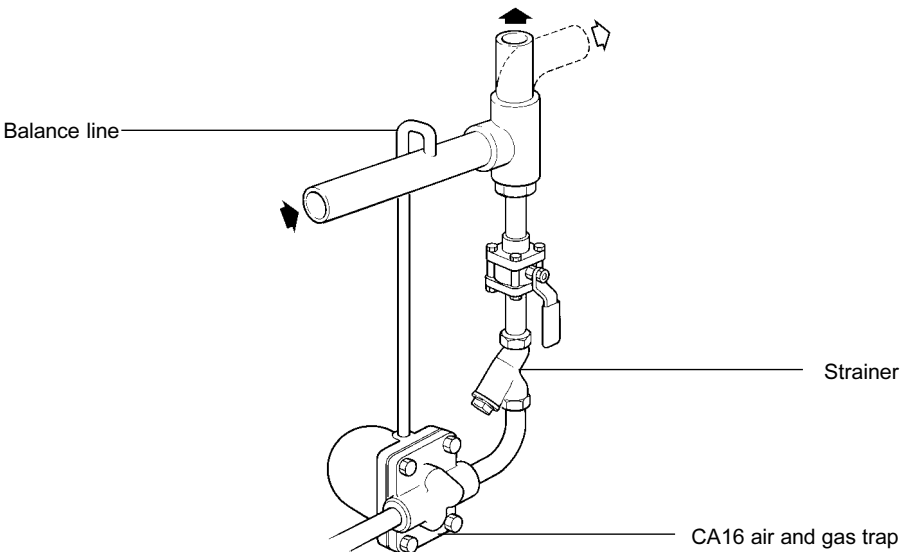

**Fig. 3 Method of draining foot of rising pipe or relay drain in horizontal run**

---

**Examples showing installation and balance line arrangement**

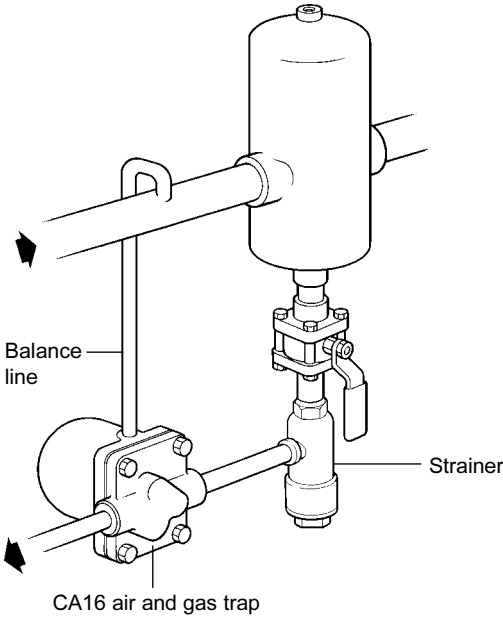

**Fig. 4**  
**Trap draining separator on compressed air main**

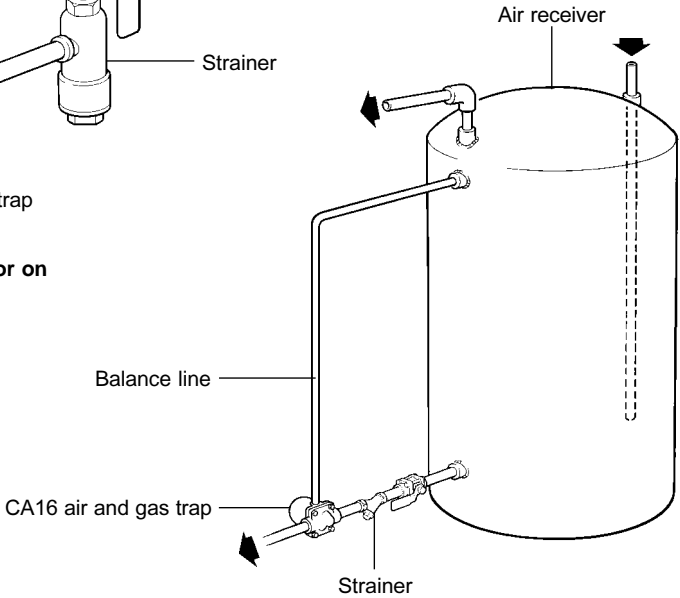

**Fig. 5**  
**Trap draining small receiver**

---

## **4. Commissioning**

---

After installation or maintenance ensure that the system is fully functional. Carry out tests on any alarms or protective devices.

---

## 5. Operation

---

The CA16(S) float trap is a continuous discharge trap, removing liquid from air and gas systems. As soon as liquid enters the main chamber of the trap, the float rises and the lever mechanism attached to it opens the main valve - keeping the system drained of liquid at all times. When air or gas arrives, the float drops and shuts the main valve tightly against the seat. The balance line is necessary to prevent the trap from becoming air locked. Float traps are renowned for their instantaneous load handling capability, clean tight shut-off and resistance to waterhammer and vibration.

---

## 6. Maintenance

---

**Note:** Before actioning any maintenance program observe the 'Safety information' in Section 1.

### Warning

The cover gasket contains a thin stainless steel support ring which may cause physical injury if not handled and disposed of carefully.

### 6.1 General information

Use only Spirax Sarco replacement parts. When reassembling make sure that all joint faces are clean. After maintenance ensure that the system is fully functioning.

### 6.2 How to fit the main valve assembly (CA16S-14):

(Refer to Fig. 6, page 8)



- Unscrew the support, pivot frame and valve seat.
- Ensure that the seat /gasket faces are clean and dry.
- Fit a new valve seat into the body. Do not use gasket paste.
- Attach the support frame and pivot frame to the body with the assembly set screws but do not tighten.
- Fit the float arm to the pivot frame using the pin and by moving the complete assembly, centre the valve head onto the seat orifice.
- Tighten the assembly set screws to the recommended torque (see Table 1).

### 6.3 How to fit the valve cone (CA16):

(Refer to Fig. 6, page 8)

- Withdraw the pivot pin to release the float and lever.
- Push out the soft Viton valve cone and replace with a new one.
- Reassemble the float and lever into the bracket and replace the pin.
- Check the operation by raising and lowering the float several times making sure that the valve cone centres properly on the seat.

**Table 1 Recommended tightening torques**

Item	Size	 or mm		N m	(lbf ft)
2	½" - 1"	17	M10 x 30	29 - 33	(21.3 - 24.3)
5	½" - 1"	17	M12	40 - 45	(29.4 - 33.1)
7	½" - 1"	Cheesehead	M5 x 20	10 - 12	(7.3 - 8.8)

## 7. Spare parts

The spare parts available are shown in heavy outline. Parts drawn in a broken line are not supplied as spares.

### Available spares

Viton valve cone CA16 (packet of 3)		<b>9</b>
Main valve assembly with float	CA16	<b>5, 6, 7, 8, 9, 15, 16, 17</b>
	CA16S-14	<b>5, 6, 7, 8+9, 15, 16, 17</b>
Complete set of gaskets (packet of 3 sets)		<b>3, 6</b>

### How to order spares

Always order spares by using the description given in the column headed 'Available spares' and state the size and type of trap.

**Example:** 1 - Main valve assembly for ½" Spirax Sarco CA16 air and gas trap.

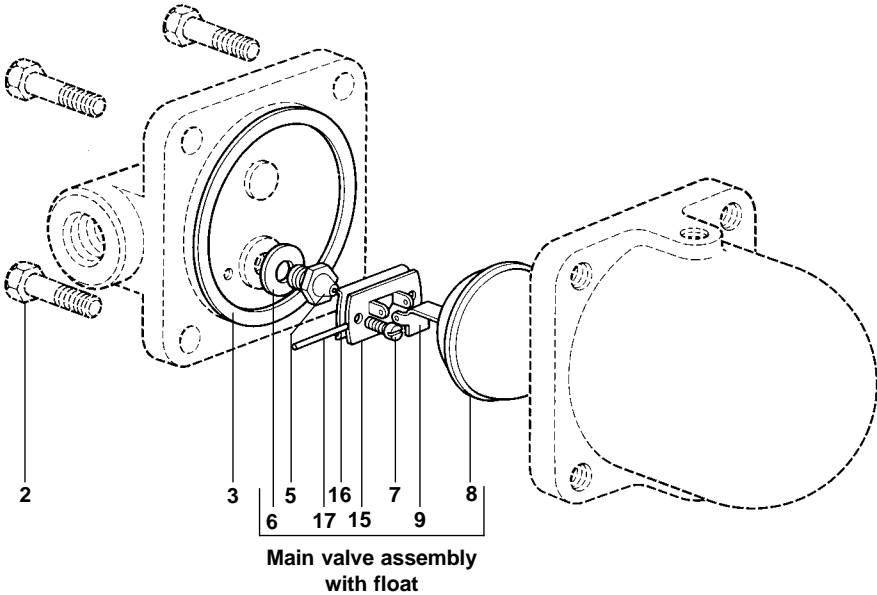

Fig. 6