



Cert. No. LRQ 0963008

ISO 9001

# spirax sarco

TI-P148-15  
ST Issue 4

## CA10S Air and Gas Trap

### Description

The CA10S is a float type automatic liquid drain trap for air and gas systems. It has a cast iron body and cover with stainless steel valve head for use on high temperature or where corrosive condensate would adversely affect a rubber valve.

### Sizes and pipe connections

3/4" screwed BSP (BS 21 parallel) or NPT.  
A 1/2" tapping is provided for a balance pipe.

### Optional extras

**Drain cock tapping**:- The cover can be drilled and tapped 2" BSP or NPT to enable a drain cock to be fitted.

### Limiting conditions

Body design conditions	PN16
PMA Maximum allowable pressure	16 bar g
TMA Maximum allowable temperature	220°C
TMO Maximum operating temperature	220°C
ΔPMX Maximum differential pressure	14 bar
Designed for a maximum cold hydraulic test pressure of 24 bar g	

### Operating range

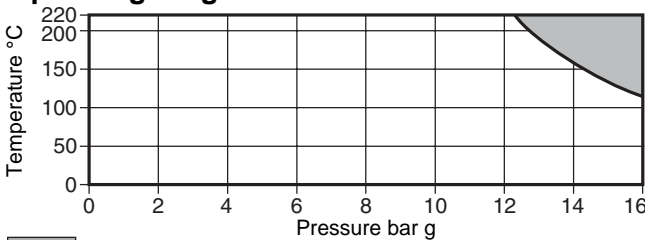

The product must not be used in this region.

### ΔPMX - Maximum differential pressure

Depending on the specific gravity of the liquid being drained.

Specific gravity	1.0	0.9	0.8	0.7	0.6
ΔPMX bar	14.0	13.8	11.7	8.6	5.0

### Material

No.	Part	Material	
1	Body	Cast iron	DIN 1691 GG 20
2	Cover bolts	Steel	BS 3692 Gr. 8.8
3	Cover gasket	Reinforced exfoliated graphite	
4	Cover	Cast iron	DIN 1691 GG 20
5	Valve seat	Stainless steel	BS 970 431 S29
6	Valve seat gasket	Stainless steel	BS 1449 304 S11
7	Pivot frame assembly set screws	Stainless steel	BS 6102 Gr. A2 Class 50
8	Ball float and lever	Stainless steel	BS 1449 304 S16
9	Pin	Stainless steel	B 970 431 529
10	Support frame	Stainless steel	BS 1449 304 S16
11	Pivot frame	Stainless steel	BS 1449 304 S16
* 12	Valve cone	Stainless steel	

\* **Note:** The valve cone of the CA10S is permanently attached to the ball float and lever

### Certification

The product is available with material certification to EN 10204 2.2 for body and cover as standard.

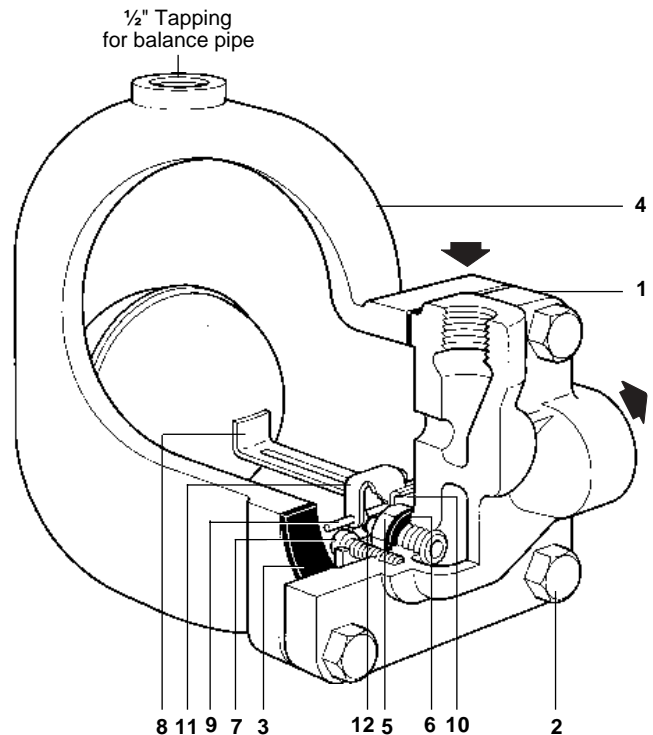

### Capacities

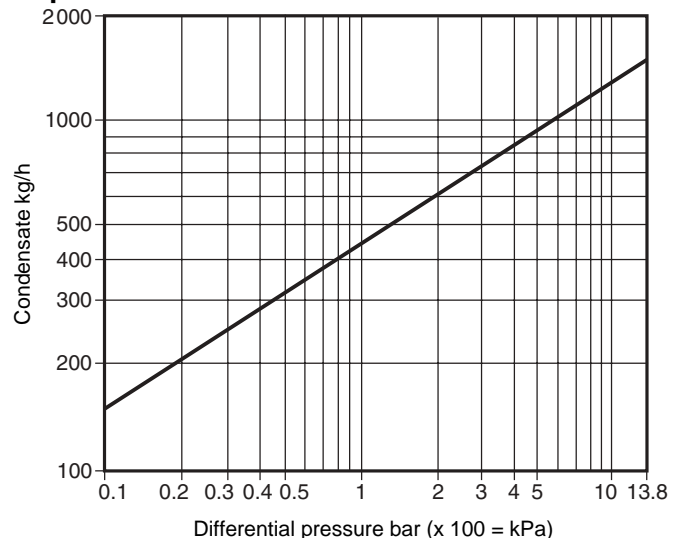

## Safety information

### Pressure

Before attempting any maintenance of the trap, consider what is or may have been in the pipeline. Ensure that any pressure is isolated upstream and downstream of the trap and safely vented to atmospheric pressure before attempting to maintain the trap. This is easily achieved by fitting Spirax Sarco depressurisation valves type DV (see separate literature for details). Do not assume that the system is depressurised even when a pressure gauge indicates zero.

### Temperature

Allow time for temperature to normalise after isolation to avoid the danger of burns and consider whether protective clothing (including safety glasses) is required.

## Installation

The air and gas trap must always be fitted with the inlet at the top so that the float mechanism is rising and falling in a vertical plane. The high point of the cover is provided with  $\frac{1}{2}$ " tapping for a balance pipe which is essential for satisfactory operation. From the tapping provided at the high point of the cover a balance pipe having a continuous rise must be fitted and connected into the space being drained.

## Maintenance

### How to fit the main valve assembly

Isolate, undo cover bolts, remove existing mechanism. Using a little jointing paste on the thread and gasket, fit the new valve seat to the body.

Attach the support frame, and pivot frame to the body with assembly set screws, but do not tighten.

Fit the float arm to the pivot frame using the pin and by moving the complete assembly centre the valve head onto the seat orifice. Hold the assembly firmly in place and tighten up set screws to the recommended tightening torque.

Check operation by raising and lowering the float several times making sure that the valve head is centring properly on the seat. Make sure all joint faces are clean, apply a thin coating of jointing paste to seat threads.

Tighten cover bolts uniformly to the recommended tightening torque. Open up isolating valve slowly.

## Disposal

The product is recyclable. No ecological hazard is anticipated with the disposal of this product providing due care is taken.

## How to order

**Example:** 1 off Spirax Sarco  $\frac{3}{4}$ " screwed BSP CA10S drain trap with cast iron body and cover.

## Dimensions / weight (approximate) in mm and kg

Size	A	B	C	D	E	F	G	Weight
$\frac{3}{4}$ "	60	111	77	195	165	217	50	6.8

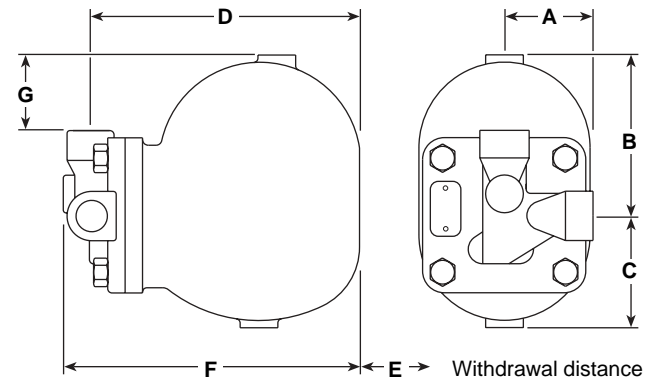

## Spare parts

The spare parts available are shown in heavy outline. Parts drawn in broken line are not supplied as spares.

### Available spares

Main valve assembly with float	<b>5, 6, 7, 8+12, 14, 15, 16</b>
Gasket set (packet of 3 sets)	<b>3, 6</b>

### How to order spares

Always order spares by using the description given in the column headed 'Available spares' and state the size and type of trap.

**Example:** 1 off main valve assembly for  $\frac{3}{4}$ " Spirax Sarco CA10S air and gas trap.

### Recommended tightening torques

Item	or mm	N m
2	17 M10 x 30	29 - 32
5	17 M12 x 8	50 - 55
7	Cheesehead M5 x 20	2.5 - 2.8

