

BCV31

DN20 - Blowdown Control Valve
Installation and Maintenance Instructions

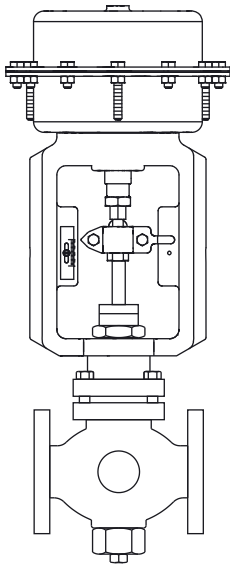

1. *Safety information*
2. *Application*
3. *Technical data*
4. *Operation*
5. *Installation*
6. *Flow settings*
7. *Maintenance*
8. *Spare parts*

1. Safety information

Safe operation of these products can only be guaranteed if they are properly installed, commissioned, used and maintained by qualified personnel (see Section 1.11) in compliance with the operating instructions. General installation and safety instructions for pipeline and plant construction, as well as the proper use of tools and safety equipment must also be complied with.

WARNING

Your attention is drawn to any National or Regional regulations concerning boiler blowdown. In the UK, guidance is given in HSE Guidance Note PM60.

WARNING

The actuator must be isolated both pneumatically and electrically before any maintenance is carried out.

The actuator must be vented before dismantling.

1.1 Intended use

Referring to the Installation and Maintenance Instructions, name-plate and Technical Information Sheet, check that the product is suitable for the intended use / application. The products listed below comply with the requirements of the European Pressure Equipment Directive 97/23/EC and carry the CE mark when so required. The products fall within the following Pressure Equipment Directive categories:

Product	Group 1 Gases	Group 2 Gases	Group 1 Liquids	Group 2 Liquids
BCV31 DN20	-	SEP	-	SEP

- i) The products have been specifically designed for use on steam, air or condensate which are in Group 2 of the above mentioned Pressure Equipment Directive. The products' use on other fluids may be possible but, if this is contemplated, Spirax Sarco should be contacted to confirm the suitability of the product for the application being considered.
- ii) Check material suitability, pressure and temperature and their maximum and minimum values. If the maximum operating limits of the product are lower than those of the system in which it is being fitted, or if malfunction of the product could result in a dangerous overpressure or overtemperature occurrence, ensure a safety device is included in the system to prevent such over-limit situations.
- iii) Determine the correct installation situation and direction of fluid flow.
- iv) Spirax Sarco products are not intended to withstand external stresses that may be induced by any system to which they are fitted. It is the responsibility of the installer to consider these stresses and take adequate precautions to minimise them.
- v) Remove protection covers from all connections and protective film from all name-plates, where appropriate, before installation on steam or other high temperature applications.

1.2 Access

Ensure safe access and if necessary a safe working platform (suitably guarded) before attempting to work on the product. Arrange suitable lifting gear if required.

1.3 Lighting

Ensure adequate lighting, particularly where detailed or intricate work is required.

1.4 Hazardous liquids or gases in the pipeline

Consider what is in the pipeline or what may have been in the pipeline at some previous time. Consider: flammable materials, substances hazardous to health, extremes of temperature.

1.5 Hazardous environment around the product

Consider: explosion risk areas, lack of oxygen (e.g. tanks, pits), dangerous gases, extremes of temperature, hot surfaces, fire hazard (e.g. during welding), excessive noise, moving machinery.

1.6 The system

Consider the effect on the complete system of the work proposed. Will any proposed action (e.g. closing isolation valves, electrical isolation) put any other part of the system or any personnel at risk?

Dangers might include isolation of vents or protective devices or the rendering ineffective of controls or alarms. Ensure isolation valves are turned on and off in a gradual way to avoid system shocks.

1.7 Pressure systems

Ensure that any pressure is isolated and safely vented to atmospheric pressure. Consider double isolation (double block and bleed) and the locking or labelling of closed valves. Do not assume that the system has depressurised even when the pressure gauge indicates zero.

1.8 Temperature

Allow time for temperature to normalise after isolation to avoid danger of burns.

1.9 Tools and consumables

Before starting work ensure that you have suitable tools and/or consumables available. Use only genuine Spirax Sarco replacement parts.

1.10 Protective clothing

Consider whether you and/or others in the vicinity require any protective clothing to protect against the hazards of, for example, chemicals, high/low temperature, radiation, noise, falling objects, and dangers to eyes and face.

1.11 Permits to work

All work must be carried out or be supervised by a suitably competent person. Installation and operating personnel should be trained in the correct use of the product according to the Installation and Maintenance Instructions.

Where a formal 'permit to work' system is in force it must be complied with. Where there is no such system, it is recommended that a responsible person should know what work is going on and, where necessary, arrange to have an assistant whose primary responsibility is safety.

Post 'warning notices' if necessary.

1.12 Handling

Manual handling of large and/or heavy products may present a risk of injury. Lifting, pushing, pulling, carrying or supporting a load by bodily force can cause injury particularly to the back. You are advised to assess the risks taking into account the task, the individual, the load and the working environment and use the appropriate handling method depending on the circumstances of the work being done.

1.13 Residual hazards

In normal use the external surface of the product may be very hot. If used at the maximum permitted operating conditions the surface temperature of some products may reach temperatures of 250°C (482°F).

Many products are not self-draining. Take due care when dismantling or removing the product from an installation (refer to 'Maintenance instructions').

1.14 Freezing

Provision must be made to protect products which are not self-draining against frost damage in environments where they may be exposed to temperatures below freezing point.

1.15 Disposal

Unless otherwise stated in the Installation and Maintenance Instructions, this product is recyclable and no ecological hazard is anticipated with its disposal providing due care is taken.

1.16 Returning products

Customers and stockists are reminded that under EC Health, Safety and Environment Law, when returning products to Spirax Sarco they must provide information on any hazards and the precautions to be taken due to contamination residues or mechanical damage which may present a health, safety or environmental risk. This information must be provided in writing including Health and Safety data sheets relating to any substances identified as hazardous or potentially hazardous.

2. Application

The BCV31 is a pneumatically actuated control valve for the blowdown of steam boilers. It is normally used with a controller as part of an automatic TDS control system, though it can also be used for other high pressure drop, low flowrate applications.

3. Technical data

Valve maximum pressure	32 bar g	(464 psi g)
Valve maximum temperature	239°C	(462°C)
Actuator maximum ambient temperature	110°C	(230°F)
Minimum air pressure	3 bar g	(44 psi g)
Maximum air pressure	6 bar g	(87 psi g)
Air consumption (20 mm travel)	0.48 litres	(0.0116 Cu. ft.)
Air supply connection	¼" NPT	

4. Operation

The valve is spring loaded to the closed position (spring retract), and is also held closed by the boiler pressure. The valve is supplied with a low flowrate 10 mm (0.4") stroke, but can be adjusted to give 15 mm (0.6") or 20 mm (0.8") stroke for increased flowrates if required.

5. Installation

Caution

Do not pressurise the spring side of the actuator housing.

Do not restrict the housing plastic vent cap.

The BCV31 will operate at any pressure between 3 bar g (44 psi g) and 6 bar g (87 psi g).

A regulated supply of filtered air is required, which should be free of oil and water. A suitable filter/regulator is the Spirax-Monnier MP2, fitted with an appropriate spring. A solenoid valve is also required. See separate literature for regulator details. The BCV31 may be mounted horizontally or vertically.

For boiler blowdown applications the ideal take-off point for the blowdown is from a boiler side connection (Figures 1 and 2), to reduce the possibility of scale entering the blowdown valve.

If the bottom connection has to be used, make a 'T' connection upstream of the main bottom blowdown valve as shown in Figure 3. We recommend that where possible the 'T' is taken off the top of the blowdown line to reduce any problems of scale.

The 1/4" BSP plug may be removed and the connection used for boiler water sampling.

Spirax Sarco recommend and can supply a sample cooler and conductivity meter.

Fit a stop valve between the boiler and the BCV31.

A check valve is recommended downstream of the BCV31.

In accordance with UK regulations and guidance notes, for **single boiler installations** the blowdown may discharge into the main blowdown line downstream of the bottom blowdown valve.

For **multi-boiler installations** the automatic blowdown lines must be separate from the main bottom blowdown line.

For further information see UK Health and Safety Executive Guidance Note PM60.

Regulations or guidance notes for other countries may differ.

Note: When installing with S11 chamber, use M12 bolts for PN16, PN25 and PN40 and ANSI 300 flanges. Use M16 bolts for BS 10 Tables 'H' and 'J' flanges. The holes in the S11 chamber are 19 mm Ø.

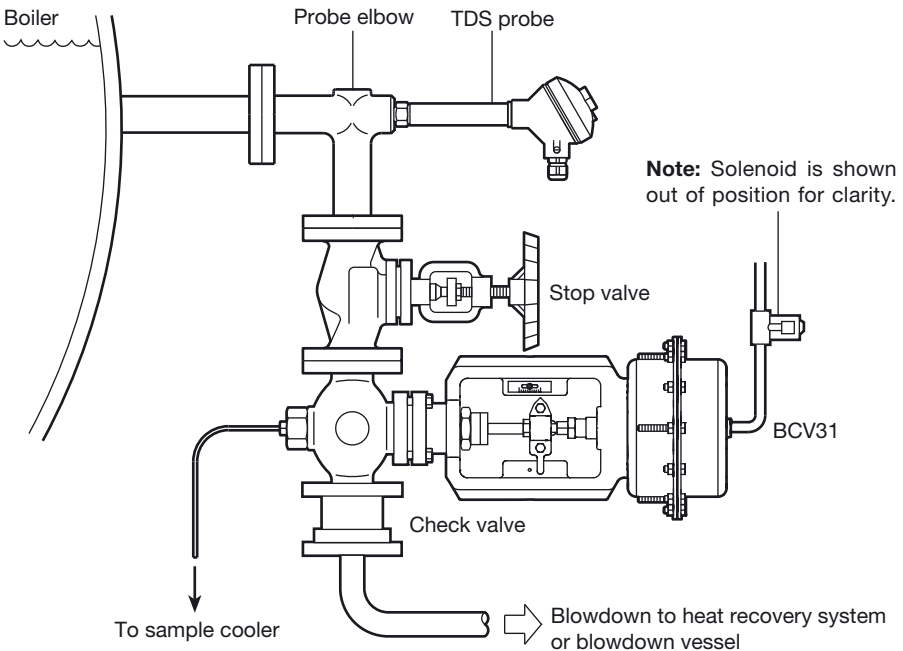

Fig. 1 Installation on a probe elbow

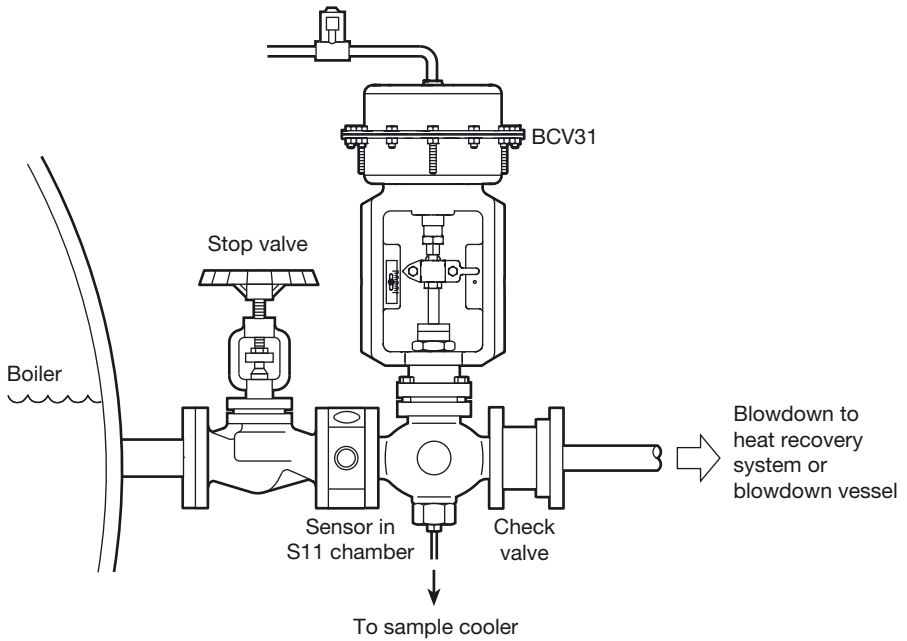

Fig. 2 Installation on a boiler side connection

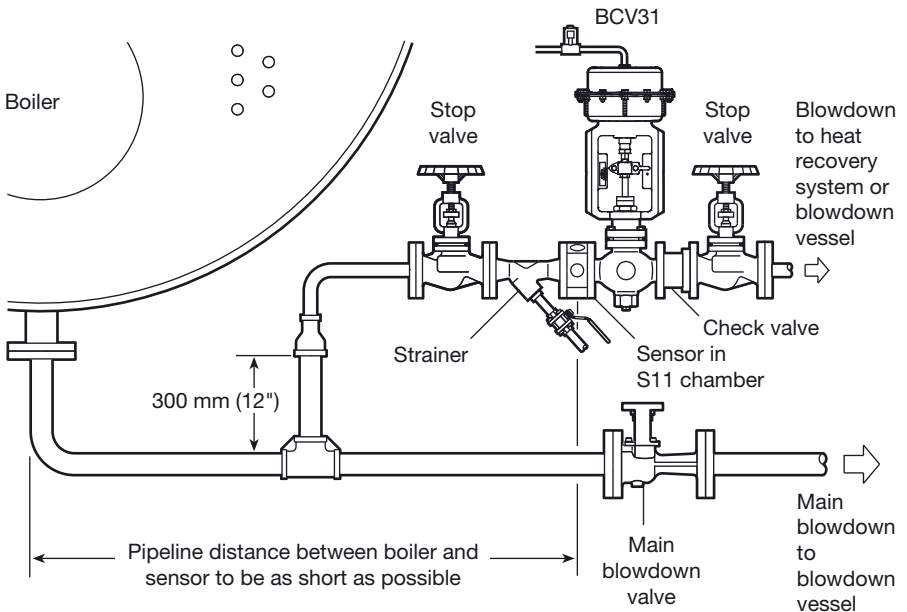

Fig. 3 Installation on a boiler with no suitable side connection

6. Flow settings

The valve is supplied with a low flowrate setting of 10 mm (3/8") stroke.

To increase the stroke to 15mm (5/8") or 20 mm (3/4"):

- Isolate the valve from the boiler pressure and energise the solenoid valve so that the air supply can be manually controlled by the regulator.
- Apply just enough air pressure to open the valve fully (see Figure 4).

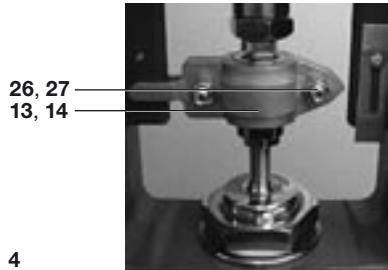

Fig. 4

- Remove the clamp nuts and screws (26 and 27), and the clamp front and rear (13 and 14).
- Turn off the air supply and allow the actuator to retract fully (see Figure 5).

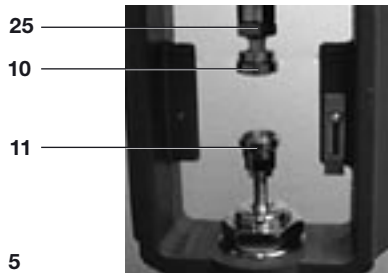

Fig. 5

- Loosen the actuator lock-nut (25), and screw the connector (10) fully into the spindle.
- Loosen the nut locking the valve stem to the adaptor (11).
- Position the adaptor so that only 8 mm of the valve stem thread is engaged (see Figures 6 and 7).



Fig. 6

Correct - 8 mm thread engagement

Caution

The valve stem must not protrude beyond the surface of the adaptor, otherwise the clamp will not fit correctly and may be damaged (see Figure 7).



Fig. 7

Incorrect - thread protruding above the adaptor

- Pull the valve stem upwards to fully close the valve.
- Measuring from the top of the stuffing box, mark the new stroke required on the valve stem - 15 mm or 20 mm (Figure 8)



Fig. 8

- Push the valve stem down so that the mark lines up with the stuffing box (Figure 9).

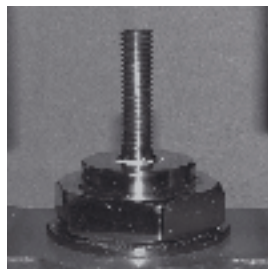

Fig. 9

- Apply air pressure to allow the actuator to descend fully.
- Unscrew the actuator connector until it just contacts the valve stem adaptor without opening the valve (Figure 10).
- Tighten adaptor and actuator lock-nuts.
- Refit the clamp, and its nuts and screws.



Fig. 10

Please note:

It may be necessary to make final adjustments to the actuator connector and the valve adaptor to ensure the clamp anti-rotation lugs engage with the yoke, and that the pointer is still on the scale.

Table 1 Blowdown valve capacities

Boiler pressure		Blowdown valve capacities					
		Low flowrates 10 mm (0.4") stroke		Medium flowrates 15 mm (0.6") stroke		High flowrates 20 mm (0.8") stroke	
bar g	psi g	kg/h	(lb/h)	kg/h	(lb/h)	kg/h	(lb/h)
5	72	380	(838)	530	(1168)	730	(1609)
7	102	460	(1015)	710	(1565)	1150	(2540)
10	145	570	(1260)	950	(2100)	1500	(3310)
15	218	700	(1540)	1150	(2540)	1650	(3640)
20	290	780	(1720)	1250	(2760)	1700	(3750)
32	464	940	(2075)	1400	(3090)	1800	(3970)

7. Maintenance

No routine maintenance is required, but we recommend that the valve and actuator are examined annually and parts replaced as necessary.

Full actuator spares fitting instructions are given in the Installation and Maintenance Instructions for PN type actuators.

The valve stem is sealed by packing rings, which can be adjusted if any leakage should occur at the valve stem (see Section 7.2).

If you need to replace spring loaded PTFE chevron seals with an adjustable packing ring set read Section 7.3.

If the bottom cover (17) is removed, fit a new stainless steel gasket (22) and tighten to 200 N m (148 lbf ft).

7.1 Components

No.	Description
1	Body
2	Bonnet
3	Seat
4	Washer (seat)
5	Valve cone
6	Cap
7	Stem
8	Wave spring
9	Gasket (bonnet)
13	Gasket
14	M8 lock-nut
15	Plug
16	'S' type gasket
17	Bottom cover
18	M10 nut
19	Stud

No.	Description
20	Guide bush
21	M30 nut/spacer
22	'S' type gasket
23	Plug ¼" BSPT
25	Actuator lock-nut
26	Clamp nuts and screws
27	Stem
32	Travel indicator plate and screw
33	Clamp front and rear
34	Actuator lock-nut
40	Bottom support ring
41	Graphite stem seal (set of 5)
42	Top support ring
43	Stuffing box
44	Gland nut

7.2 To adjust the valve stem packing rings:

- Turn the adjustable gland nut (44) clockwise one flat (60°) at a time, then operate the valve several times. Repeat if still leaking.

Fig. 11

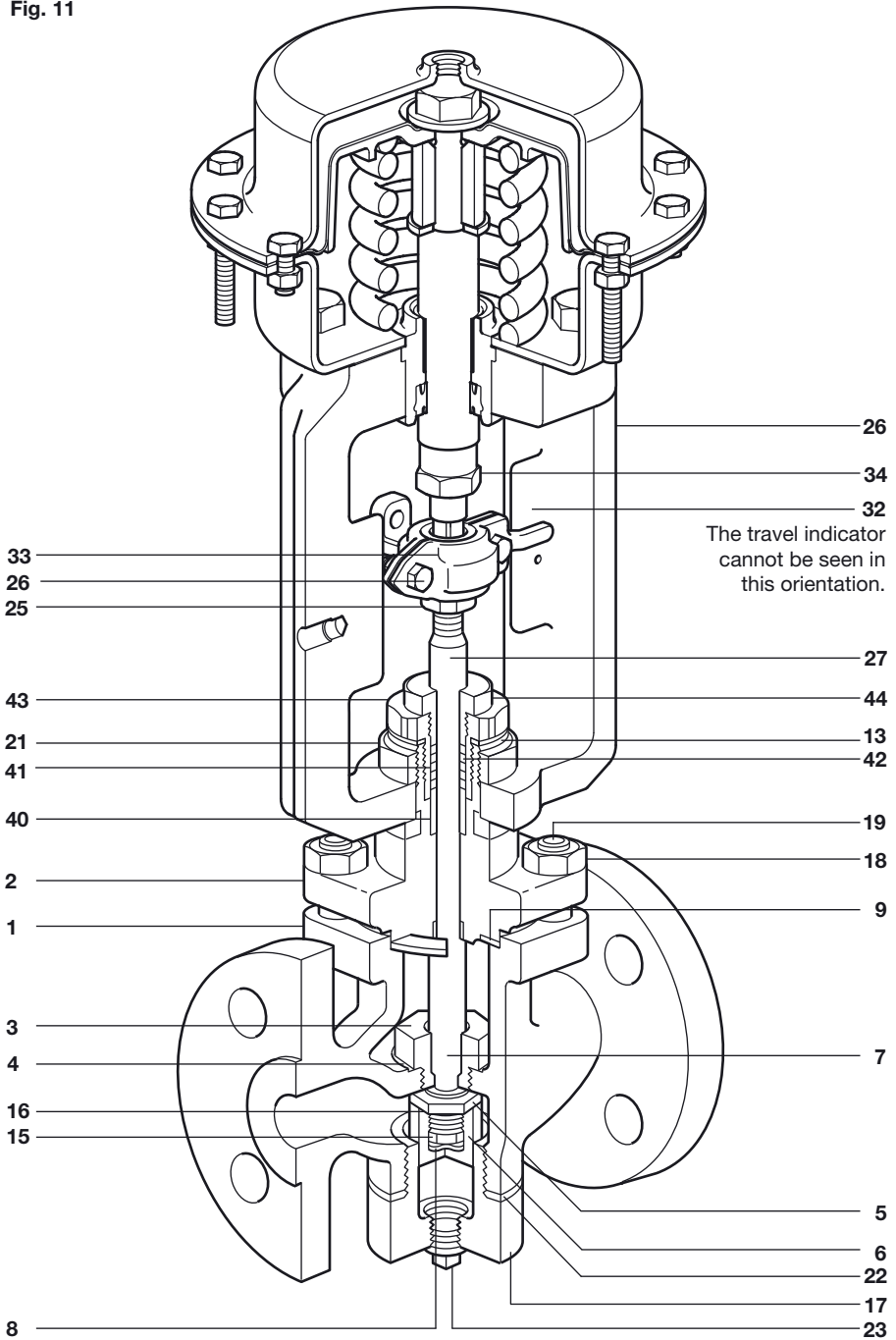

7.3 To replace spring loaded PTFE chevron seals with an adjustable packing ring set:

- Remove the actuator.
- Remove and discard the existing stuffing box, PTFE chevron seals, guide bush, and spring.
- Ensure the valve stem and bonnet are clean.

7.3.1 If the new seal set is supplied assembled into the stuffing box:

- Fit the bottom support ring (40, see Figure 12) over the valve stem and locate in the valve bonnet with its small diameter downwards.
- Fit the stuffing box gasket (13) to the stuffing box (43), and pass the stuffing box assembly over the valve stem (7).

WARNING: Handle the gasket with care - it is fragile, and has a sharp reinforcement.

- Screw the stuffing box into the valve bonnet and torque to 25 - 30 N m (18 - 22 lbf ft).
- Ensure the gland nut (44) is finger tight against the top support ring (42), then move the valve stem up and down over its full travel five or six times to bed in the packing rings.
- Tighten the gland nut by two flats (120°).
- Reassemble the actuator, pressurise the system, and operate the valve five or six times.
- Adjust the gland nut to stop any leaks.

7.3.2 If the new seal set is supplied as separate components:

- Fit the top support ring (42), chamfer first, into the stuffing box (43). (See Figure 12).
- Fit the five packing rings (41) into the stuffing box from below, so the thread in the top of the stuffing box cannot damage the rings. Ensure that the splits in the packing rings are staggered. Tip:- Use the bottom support ring (40) as a temporary tool to push the packing rings into place.
- Fit the bottom ring support over the valve stem (7) and locate in the valve bonnet with its small diameter downwards.
- Fit the gland nut (44), and tighten finger-tight only at this stage.
- Fit the stuffing box gasket (13) to the stuffing box, and pass the stuffing box assembly over the valve stem.

WARNING: Handle the gasket with care - it is fragile, and has a sharp reinforcement.

- Screw the stuffing box into the valve bonnet and torque to 25 - 30 N m (18 - 22 lbf ft).
- Move the valve stem up and down over its full travel five or six times to bed in the packing rings.
- Tighten the gland nut by two flats (120°).
- Reassemble the actuator, pressurise the system, and operate the valve five or six times.
- Adjust the gland nut to stop any leaks.

7.4 Replacing the valve seat:

- When replacing the valve seat (3), it will be necessary to fit a guide bush (20) into the valve bonnet if one is not already fitted. A guide bush is included in the 'Valve cone, seat and stem spares set' (see Section 8). The bush is a press fit - fit with chamfered end first.
- It is recommended that a suitable press is used to insert the bush flush into the bonnet.
Note: to avoid damage, the bush must not be hammered.

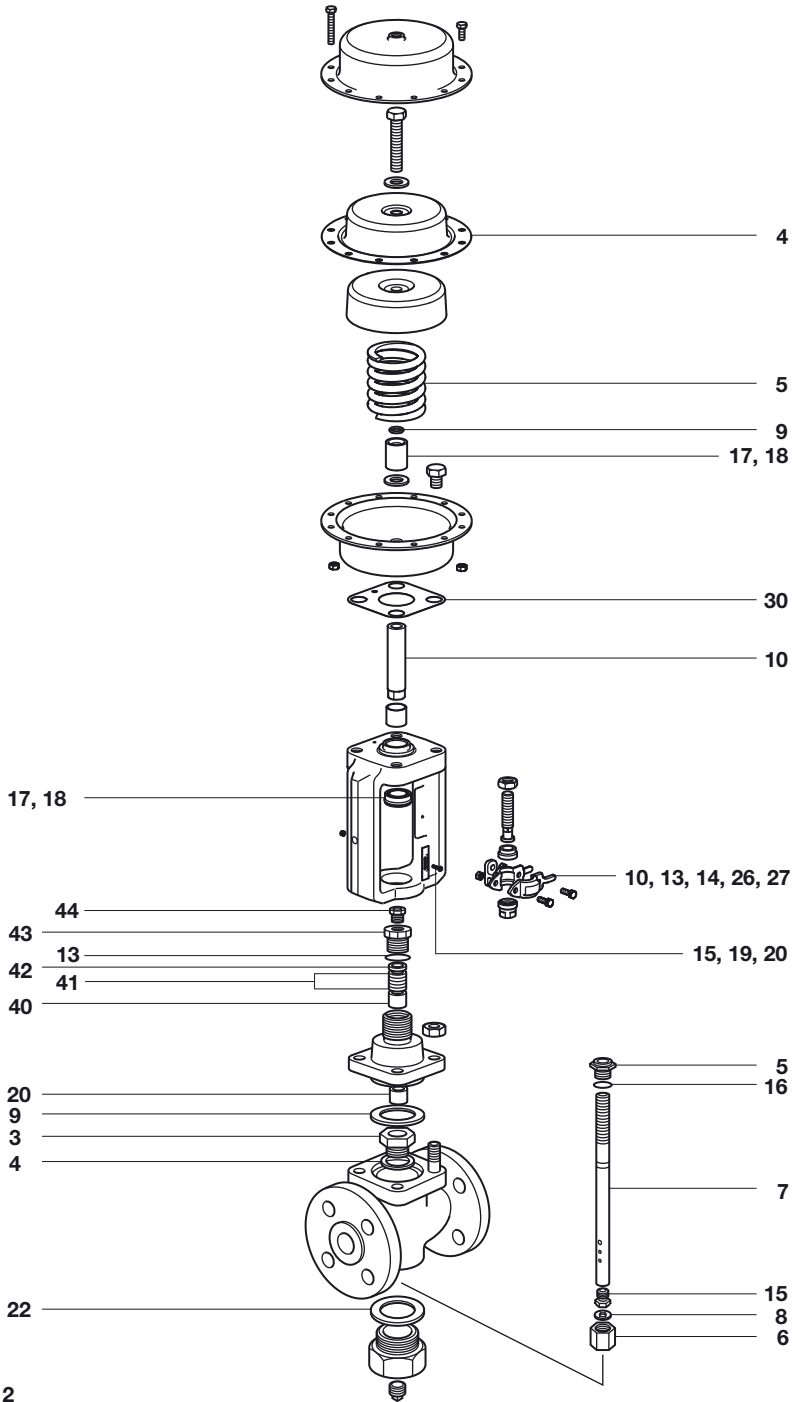

Fig. 12

8. Spare parts

Available spares for BCV31 valve

A gasket and packing set, and a valve cone and stem set are available.

An adjustable stuffing box kit is also available, enabling a valve with spring loaded PTFE seals to be converted to the adjustable graphite seal system*.

The spare parts are available as indicated below. No other parts are available as spares.

Available spares

	Gasket and packing set	Stock No. 4034682	4, 9, 13, 16, 22, 41
Valve	Valve cone, seat and stem set	Stock No. 4034683	3, 5, 6, 7, 8, 15, 16, 20 + Gasket and packing set
	* Adjustable stuffing box kit	Stock No. 4034684	40, 42, 43, 44 + Gasket and packing set
	Stem seal kit		17, 18, 30
	Diaphragm kit		4, 9
Actuator	Travel indicator kit		15, 19, 20
	Spring kit		5
	Linkage kit		10, 13, 14, 26, 27
	(suitable for MK1 and Mk2 valves)		

How to order spares

Always order spares by using the description given above, and state the size and flange type of blowdown control valve.

Example: 1 off Gasket and packing set, Stock No. 4034682, for a Spirax Sarco DN20 BCV31 blowdown control valve having flanged EN 1092 PN40 connections.

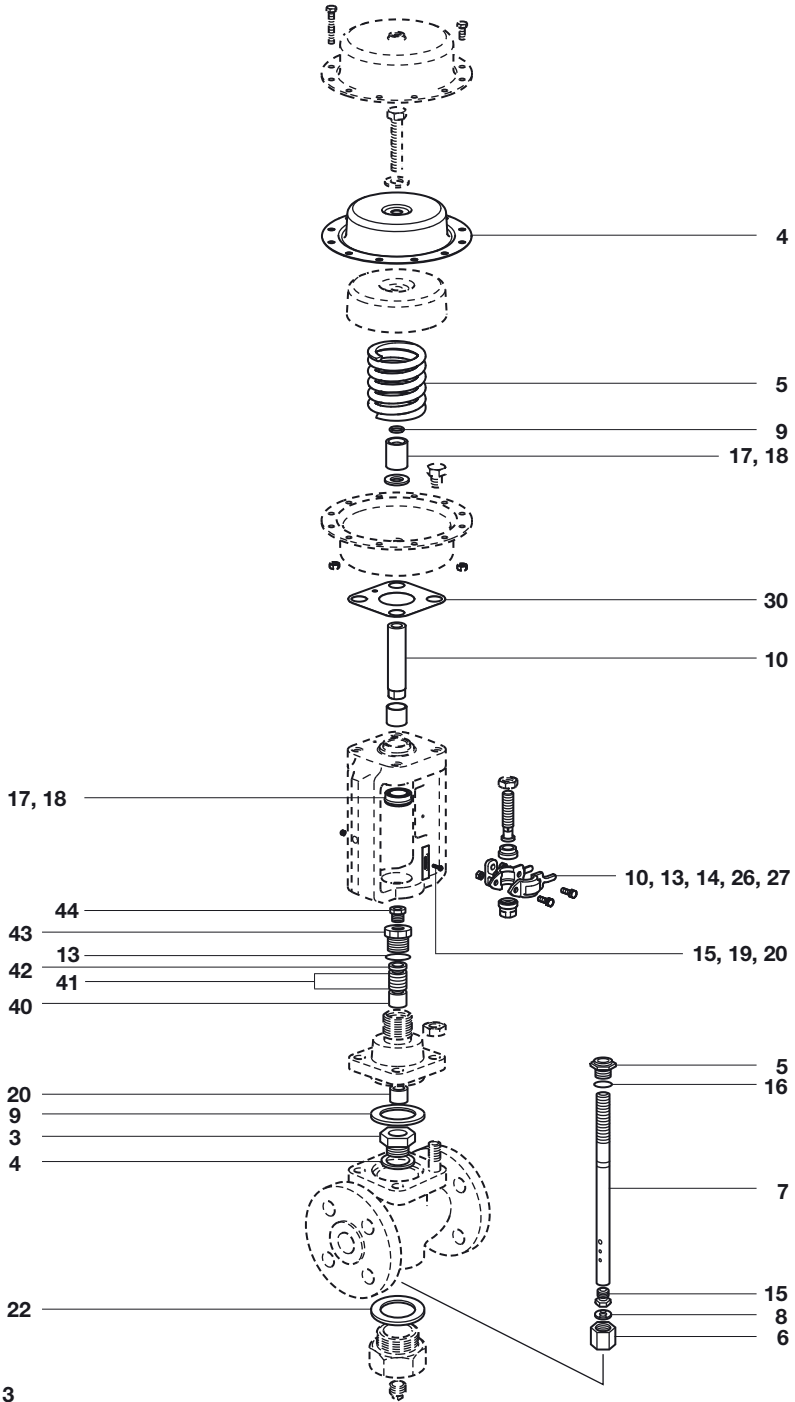

Fig. 13

