

Pilot Valve Diaphragm set for the DP17 and DP27 plus Pilot Valve Chamber Assembly for the DP17 Fitting Instructions

Warning

For the full Installation and Maintenance Instructions, inclusive of safety information, see the relevant documents supplied with the product and listed below:

Valve type	IM reference no.
DP17, DP17E, DP17G, DP17R and DP27G	IM-P100-05
DP17T and DP17TE	IM-P101-04
DP27, DP27E and DP27R	IM-P470-03
DP27T	IM-P470-09
37D and 37DE	IM-P102-04

Note:

Installation and Maintenance Instructions are available separately from Spirax Sarco.

Fitting instructions

For the DP17 and all variants except the DP17R and 37D:

- Isolate the pressure reducing valve and zero the pressure.

For the DP17R and DP27R (not shown):

- Isolate the actuating air supply and zero the pressure.

For the 37D (not shown):

- Allow the sensor bulb to cool before dismantling the valve.

For the DP27 and all variants except the DP17R and DP27R:

- Isolate the reducing valve and zero the pressure.

1. Release the lock-nut.
2. Turn the adjustment screw anticlockwise. Ensure there is no compression on the pressure adjustment spring
3. **For the DP17 and all variants:** Slide out the 'C' washer.
4. Remove the cover.
5. **For the DP17 and all variants:** Remove the pressure adjustment spring and upper and lower spring plates.

For the DP27 and all variants:

Undo the 4 off spring housing securing nuts and remove the spring housing. Then proceed to remove the pressure adjustment spring and the top spring plate.

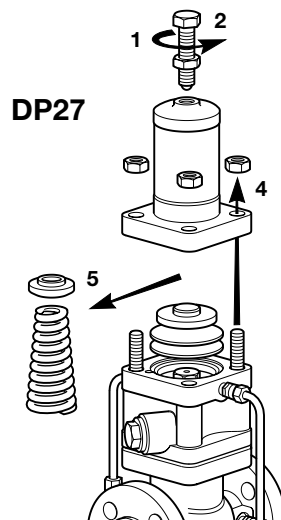
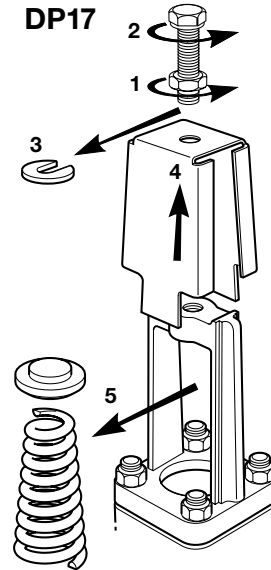

6. Unscrew the spring housing securing nuts and remove the spring housing and lower spring plate. Note that this has already been actioned under Step 5 for the DP27 and variants.

For pilot diaphragm replacement only go to Step 14.

7. For DP17 and all variants, pilot valve chamber replacement

Unscrew the unions and release the pipework.

8. Remove the pilot valve housing.
9. The main valve screen can now be removed for replacement or cleaning at this stage.
10. Ensure the gasket faces are clean.

Safety note: Care should be exercised when handling gaskets since the stainless steel reinforcing strip can easily inflict cuts.

11. Check that the main valve return spring is still in position.

Supplementary note: Fitting the main valve return spring.

Due to improvements in the design of the pilot valve chamber assembly for older DP17 valves the existing main valve return spring may not fit. New spares sets, maintenance kits and pilot valve chamber assemblies will as standard contain a slightly larger main valve return spring to replace the existing spring.

12. Fit the new gasket (see the 'Safety note' in Step 10).
13. Replace the main valve screen and assemble the pilot valve housing.
14. Fit the two new pilot valve diaphragms, if not renewing make sure they are fitted the same way round as they were removed and that all contact faces are clean. Diaphragms showing signs of wear or damage must be replaced. New diaphragms should be fitted such that the precoated sealant (which is only applied to one diaphragm) faces down contacting the sealing face of the diaphragm chamber.
15. **For the DP17, DP27 and all variants except the DP17R, DP27R and 37D** - Assemble the pilot valve spring housing assembly and tighten the nuts to the recommended tightening torques shown in Table 1.
For the DP17R and DP27R - Assemble the air control block and tighten the nuts to the recommended tightening torques shown in Table 1.
For the 37D - Assemble the pilot valve temperature control system and tighten the nuts to the recommended tightening torques shown in Table 1.
16. Refit the pipework and retighten the unions to ensure an effective seal.
17. Reassemble in reverse order.

The valve can now be brought back into commission.

Table 1 Recommended tightening torques

Size of valve	Nut size	Tightening torques	
		N m	(lbf ft)
DN15, DN20, DN25 and DN32	M10	40 - 50	(30 - 37)
DN40 and DN50	M12	45 - 55	(33 - 40)

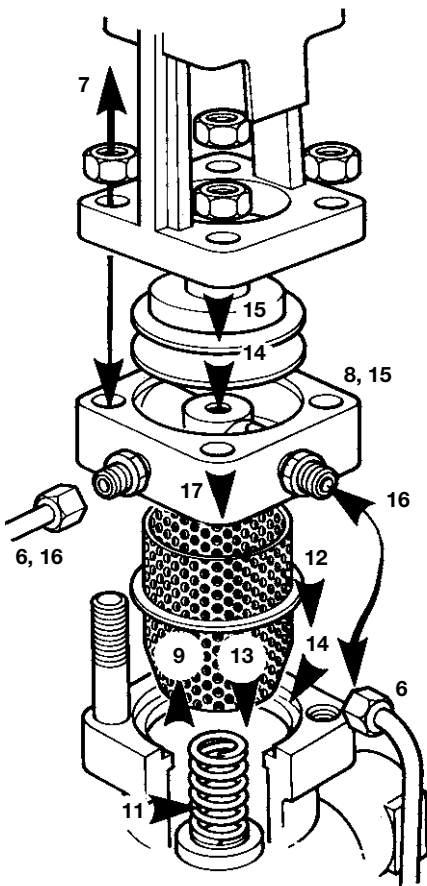

DP17

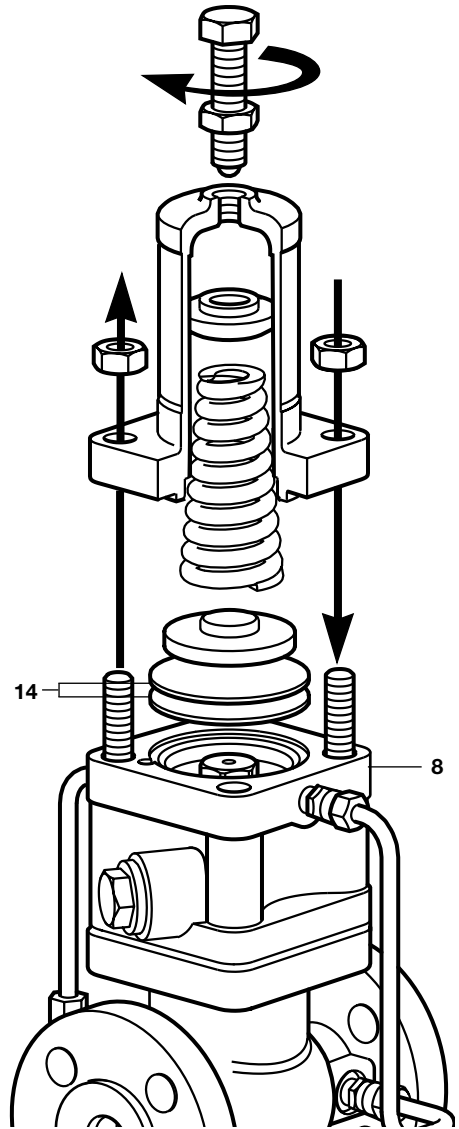

DP27

