

M10HP Ball Valve
Screwed, SW and BW versions
Installation and Maintenance Instructions

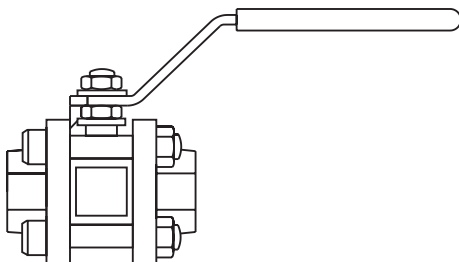

1. *General safety information*
2. *General product information*
3. *Installation*
4. *Commissioning*
5. *Operation*
6. *Maintenance*
7. *Spare parts*

1. *General safety information*

Safe operation of the unit can only be guaranteed if it is properly installed, commissioned and maintained by a qualified person (see Section 11 of the attached Supplementary Safety Information) in compliance with the operating instructions. General installation and safety instructions for pipeline and plant construction, as well as the proper use of tools and safety equipment must also be complied with.

Isolation

Consider whether closing isolating valves will put any other part of the system or personnel at risk. Dangers might include; isolation of vents and protective devices or alarms. Ensure isolation valves are turned off in a gradual way to avoid system shocks.

Pressure

Before attempting any maintenance consider what is or may have been in the pipeline. Ensure that any pressure is isolated and safely vented to atmospheric pressure before attempting to maintain the product, this is easily achieved by fitting Spirax Sarco depressurisation valves type DV (see separate literature for details). Do not assume that the system is depressurised even when a pressure gauge indicates zero.

Temperature

Allow time for temperature to normalise after isolation to avoid the danger of burns and consider whether protective clothing (including safety glasses) is required.

Hydraulic locking

Ball valves are prone to lock-up when used on certain heating/cooling applications where both steam and liquid will pass through the valve. This is caused by liquid trapped in the ball during closure being heated to create a high hydraulic pressure inside the ball cavity. To prevent this, during manufacture, a minute hole is drilled in the ball, so that in the closed position, any excess pressure will be relieved. Spirax Sarco ball valves for these applications are clearly marked to allow the valve to be correctly installed, such that, when closed, the hole is facing the steam source.

Cap gaskets

If the 'O' rings have been subjected to a temperature approaching 315°C (599°F) or higher, they may have decomposed and formed hydrofluoric acid. Avoid skin contact and inhalation of any fumes as the acid can cause skin burns and damage to the respiratory system.

Disposal

The product is recyclable. No ecological hazard is anticipated with the disposal of this product providing due care is taken.

— 2. General product information —

2.1 General description

The M10HP is supplied either as a screwed or welded three piece body ball valve comprising a body and two end-caps designed for high pressure gas service.

Available types

M10HP2RB	Zinc plated carbon steel body, Acetal seats, reduced bore.
M10HP2FB	Zinc plated carbon steel body, Acetal seats, full bore.
M10HP3RB	Stainless steel body, Acetal seats, reduced bore.
M10HP3FB	Stainless steel body, Acetal seats, full bore.

Note: For additional information see Technical Information Sheet, T1-P133-45.

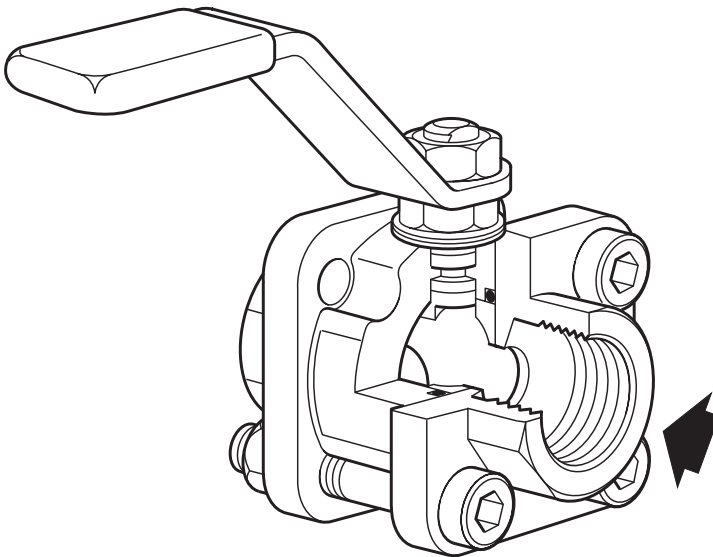

Fig. 1 M10HP ball valve

2.2 Sizes and pipe connections

1/4", 3/8", 1/2", 3/4", 1", 1 1/4", 1 1/2" and 2", (**Note:** The 2" is only available with reduced bore - RB). Screwed BSP, BSPT, NPT, SW and BW. All versions are available either as full bore (FB) or reduced bore (RB) with the exception to the 2" which is only available as RB.

2.3 Limiting conditions

Maximum operating temperature	80°C @ 210 bar g	
	1/4", 3/8" and 1/2" RB	350 bar
Maximum operating pressure (MOP)	1/2" FB; 3/4" and 1" RB	315 bar
	1" FB; 1 1/4", 1 1/2" and 2" RB	280 bar
Designed for a maximum cold hydraulic test pressure of 1.5 x MOP		

2.4 Operating range

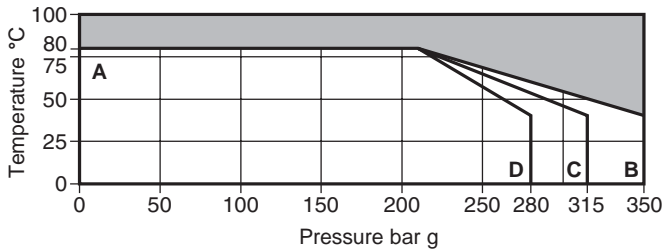

 The product must not be used in this region.

- A - B 1/4", 3/8" and 1/2" RB
- A - C 1/2" FB; 3/4" and 1" RB
- A - D 1" FB; 1 1/4", 1 1/2" and 2" RB

3. Installation

Note: Before actioning any installation observe the 'Safety information' in Section 1.

Although the valve has great structural integrity, severe misalignment and/or the pulling effect of incorrect pipe length will have a detrimental effect on the valve and must be avoided. Particular attention should be paid to correct pipe alignment such that the inlet pipework and valve are all on the same axis.

Valves are for on/off applications and may be operated manually.

Wherever practicable, valves should be installed where there is adequate space available so that they can be conveniently operated and maintained.

Before installing a valve, check to ensure that size, pressure rating, materials of construction, end connections, etc. are suitable for the service conditions of the particular application.

Care must be taken to ensure that all dirt which may have accumulated in the valve during storage is removed before installation, maintain cleanliness during installation since the introduction of dirt can result in damage to the valve seats and operating mechanism.

To minimise the danger of abrasive particles damaging the seats, pipeline strainers should be fitted upstream of the valves.

Install the valve with the handle in a suitable position. Although the preferred position is with the spindle vertical, the valve can be installed in any position on gas service (see Fig. 2 below).

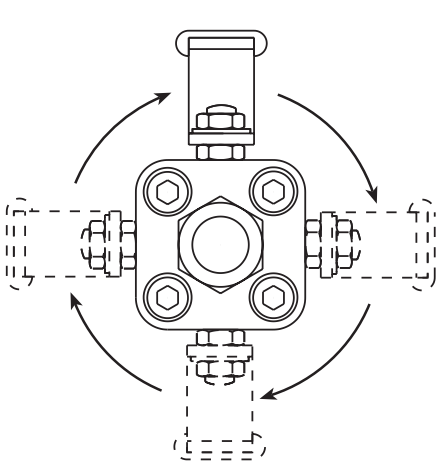

Fig. 2

Valves should be installed into the pipeline in the fully closed position. Prior to welding into the pipeline, it will be necessary to:

1. Dismantle the end caps from the body.
2. Remove the Acetal seats.
3. Weld each end cap to the pipeline.
4. Replace the Acetal seats.
5. Reassemble.

Always open valves slowly to avoid system shocks.

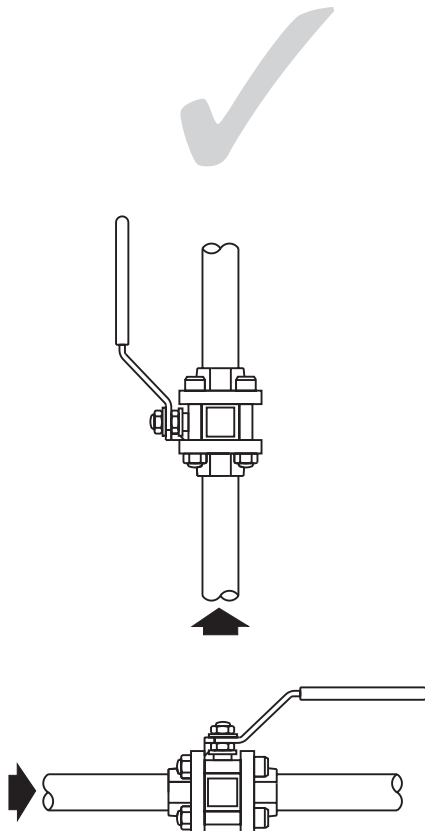

Fig. 3 Correct installation

4. Commissioning

After installation or maintenance ensure that the system is fully functioning. Carry out tests on any alarms or protective devices.

5. Operation

The valve is operated manually by a handle. Special care must be taken to ensure that the movement is made in the correct direction.

The valve can be used as an on/off valve and can be operated fully open or fully closed.

6. Maintenance

Note: Before actioning any maintenance programme observe the 'Safety information' in Section 1.

6.1 General information

As with all mechanical devices, regular maintenance is the most efficient means of ensuring continued operational efficiency.

Regular scheduled inspection of all valves is essential especially on valves which are operated only occasionally.

6.2 General maintenance

Maintenance work can be carried out without removing the complete ball valve from the pipeline. Remove the four nuts (16) and bolts (15). The complete body assembly can then be removed and any new parts fitted.

Whenever the valve is dismantled, the Viton cap gaskets ('O' ring - 17) must be replaced before reassembly.

6.3 To replace seats and 'O' ring

- Remove the body as described in Section 6.2.
- With the body removed, remove seats (5).
- Fit new seats (5) and 'O' ring (17), pushing them into the body recesses.

6.4 To replace stem seals

- Remove body as described in Section 6.2.
- Remove nuts (10), (12) and the Belleville washers (9).
- Replace stem seals (6 and 7).

6.5 Reassembly

Reassemble in reverse order to instructions given above. The securing bolts and nuts (15, 16) should be tightened to the recommended torques shown in Table 1 opposite.

After 24 hours in service, retighten body bolts.

Table 1 Recommended tightening torques

Item no.	Part	Size	N m	(lbf ft)
15	Securing bolts	¼", ⅜", ½" RB	13	9.6
		½" FB ¾" RB	13	9.6
		¾" FB 1" RB	30	22.1
16	Nuts	1" FB 1¼" RB	30	22.1
		1¼" FB 1½" RB	40	29.5
		1½" FB 2" RB	57	42.0
9	Stem nut	¼", ⅜", ½" RB	10.8 - 13.5	7.9 - 9.9
		½" FB ¾" RB	10.8 - 13.5	7.9 - 9.9
		¾" FB 1" RB	17.5 - 20.3	12.9 - 15.0
		1" FB 1¼" RB	17.5 - 20.3	12.9 - 15.0
		1¼" FB 1½" RB	17.5 - 20.3	12.9 - 15.0
		1½" FB 2" RB	17.5 - 20.3	12.9 - 15.0

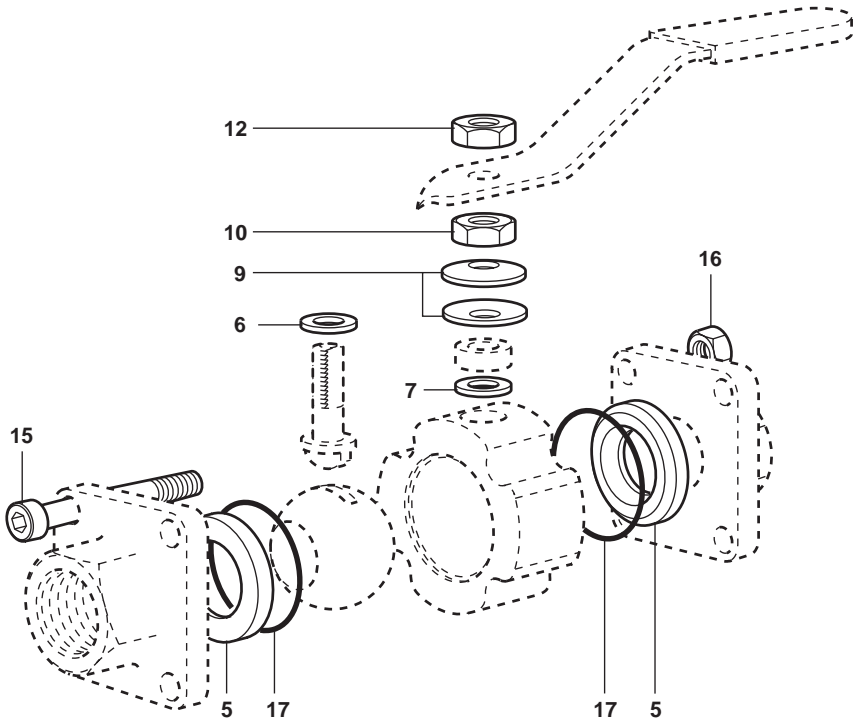

Fig. 4 M10HP screwed version shown

7. Spare parts

The spare parts available are shown in heavy outline. Parts drawn in broken line are not supplied as spares.

Available spares

Seat, stem seals, seat seal set and cap gaskets

5, 6, 7, 17

How to order spares

Always order spares by using the description given in the column headed 'Available spares' and state the size and type of ball valve.

Example: 1 - Seat, stem seals, seat seal set and cap gaskets for a 1" M10HP3FB ball valve.

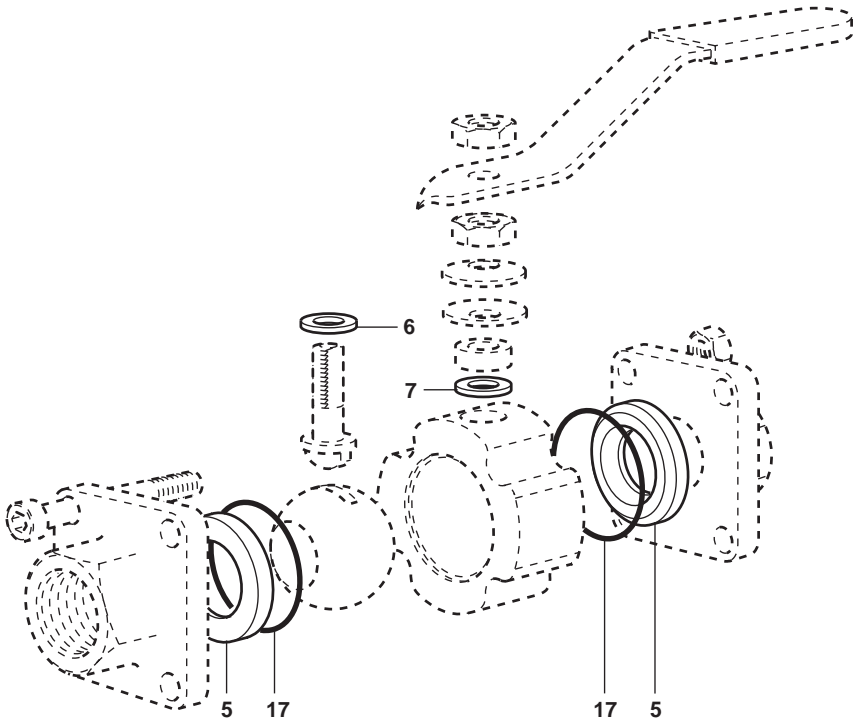

Fig. 5 M10HP screwed version shown